

LIFEPO4 Battery Specification

磷酸铁锂电池规格书

**MODEL/型号: LFP100-12.8 12.8V100Ah
(LFP48174133 3.2V100Ah-4S1P)**

MERITSUN[®]

Lithium Energy Solution

1. 使用范围 Scope

本标准只适用于广州美力特动力科技有限公司所生产的磷酸铁锂充电电池

This specification only applies to the reference battery in this specification and manufactured by MeriTech Power Limited.

2. 主要参数 Rating

	项目 Item	参数 Rating	备注 Note
电芯 Cell	电池类型 Type	LiFePO4 Battery	
	电芯型号 Cell Model	LFP48174133-3.2V100AH	
	标称容量 Nominal Capacity	100Ah	Discharge : 0.2C Cut-off Voltage:2.5V
	最小容量 Minimum Capacity	100Ah	Discharge : 0.2C Cut-off Voltage: 2.5V
	标称电压 Nominal voltage	3.2V	
	内阻 Internal Impedance	≤5mΩ	
	尺寸 Dimension	MAX. 48.5*176*135mm	
	重量 Weight	Approx. 2.15kg	
电池组 Batterypack	组合方式 Pack Method	4S1P	
	标称容量 Nominal Capacity	100Ah	Discharge : 0.2C Cut-off Voltage:10V
	最小容量 Minimum Capacity	100Ah	Discharge : 0.2C Cut-off Voltage: 10V
	标称电压 Nominal Voltage	12.8V	
	能量 Energy	1280Wh	
	充电电压 Charge Voltage	14.6V	
	放电截止电 Discharge cut-off voltage	10V	
	充电方式 Charge Method	CC/CV	
	标准充电电流 Standard Charge Current	20A	
	最大充电电流 Max. Charge Current	100A	
	标准放电电流 Standard Discharge Current	20A	
	最大持续放电电流 Max. Continues Discharge current	100A	
	循环寿命 Cycle Life	2000 times (周)	100%
	内阻 Internal Impedance	≤60mΩ	
	尺寸 Dimension	331*171*220 mm	
	引出线 Output Wire		
插头 Output Connector	/		
重量 Weight	Approx. 12kg		

	工作温度范围 Working Temperature Range	Charge: 0°C--45°C Discharge: -20°C--60°C	
	储存温度 Storage Temperature	-10°C--45°C	

3.1 保护板参数 PCM Parameter

No.	Item		Standard
1	充电电流 Charge Current		≤100A
2	放电电流 Discharge Current		≤100A
3	Overcharge	过充保护电压 Over-Charge Detect Voltage	3.90±0.05 V
		过充延时 Over-Charge Delay Time	0.5-2S
		过充恢复电压 Over-Charge Reset Voltage	3.60±0.10 V
4	Over-discharge	过放保护电 Over-Discharge Detect Voltage	2.00±0.10 V
		过放延时 Over-Discharge Delay Time	10-400mS
		过放恢复电 Over-Discharge Reset Voltage	2.70±0.10V
5	Over-current	过流保护电流 Over-Current Detect Current	300±50 A
		过流延时 Over-Current Delay Time	5-60ms
		条件 Reset	Release load
6	Short Circuit	Detect Status	External Short Circuit
		Reset	Release load
7	Resistance		≤20mΩ

3.2 电路原理图 Product Circuit diagram

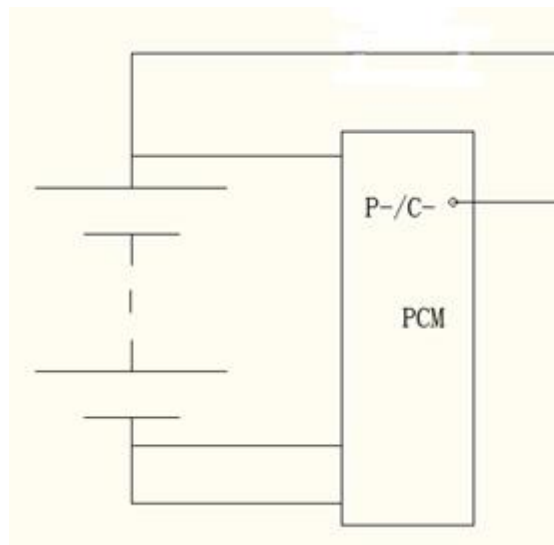

4. 外观 Appearance

按照此规格书要求，正常储存或操作，电池不应出现破裂、划痕、变形、污迹、电解液泄露等不良现象。
It shall be free from any defects such as scratch, distortion, contamination and leakage.

5. 电池性能及测试条件 Performance

5.1 标准测试条件 Standard Test Condition

电池应在到货日期一个月内在测试，除非规格书中特别注明，本规格书规定的测试条件为：温度： $20\pm 5^{\circ}\text{C}$ ，相对湿度： $65\pm 20\%$ ，标准充电后，19A 放电到截止电压的容量，为电池的标准容量，允许 5 次循环，其中一次达到最小容量即为合格

The battery shall be evaluated within 1 month from the arrival date.

Unless otherwise stated in these specifications, the following test shall be carried out in an ambient temperature of $20\pm 5^{\circ}\text{C}$, relative humidity of $65\pm 20\%$

Discharge capacity when the battery is discharged at 19A to 10V after being standard charged. Five cycles are permitted for this test. The test shall be terminated at the end of the first cycle which meets the requirement.

5.2 测试仪器 Testing Instrument or Apparatus

5.2.1 尺寸测量工具 Dimension Measuring Instrument

测量尺寸的仪器精度应大于等于 0.01mm.

The dimension measurement shall be implemented by instruments with equal or more precision scale of 0.01mm specified.

5.2.2 万用表和安培计 Voltmeter and Ammeter

测量电池电压时万用表内阻应大于 $10\text{K}\Omega/\text{V}$ ，电流表及电线在内的总内阻应小于 0.01Ω .

Voltmeters and ammeters shall be equal or more precision instruments of $10\text{K}\Omega/\text{V}$ and 0.01Ω .

5.2.3 内阻仪 Impedance Meter

内阻测试仪测试原理应为交流阻抗法(1kHz LCR)

Impedance shall be measured by a sinusoidal alternating current method (1kHz LCR meter)

5.3 标准充电 Standard Charge

锂离子电池专用充电器 14.6V/20A，充电时间约 6 小时

Standard charge means charging for 6hours using 14.6V/20A charger

5.4 标准放电 Standard Discharge

电池以 20A 恒流放电到截止电压

Standard discharge means discharging at 20A down to 10V

5.5 电池性能 Electrical Performance

名称 Item	测试方法及条件 Condition	要求 Specification
开路电压 Open-Circuit Voltage	标准充电后，24 小时内测量的开路电压 The open-circuit voltage shall be measured within 24hours after standard charge	$\geq 13.2\text{V}$
电池容量 Battery Capacity	标准充电后,搁置 1 小时,然后用 20A 电流放电至截止电压，记录放电时间 The discharge time at 20A shall be measured after standard charge at $20\pm 5^{\circ}\text{C}$ and rest 30mins	$\geq 100\%$

循环寿命 Cycle Life	在 20±5℃ 状态下,用 20A 恒流充电至充电电压,再恒压直至充电电流≤0.02C; 搁置 1 小时,再用 20A 电流放电至截止电压; 又搁置 1 小时,循环 2000 次, 记录放电时间 The discharge time on standard discharge shall be measured after 2000 cycles of standard charge and discharge at 20±5℃	≥80%
荷电保持能力 Charge(capacity) retention	在 20±5℃ 状态下,标准充饱电后,电芯搁置 28 天,然后用 20A 放电至截止电压,记录放电时间 The discharge time at 20A shall be measured after standard charge and then storage at 20±5 °C for 28days	≥80%
温度性能 1 Temperature Characteristic1	标准充电后,在 55±2℃ 条件下贮存 5h, 然后用 20A 放电至截止电压, 记录放电时间 After standard charging at 20±5℃, laying the battery at 55 °C for 2hour, then discharge at 20A to 10V, record the discharge time	≥80%
温度性能 2 Temperature Characteristic2	标准充电后,在 -10±2℃ 条件下贮存 16-24h, 然后用 20A 放电至截止电压, 记录放电时间 After standard charging at 20±5℃, laying the battery at -10 °C for 4hour, then discharge at 20A to 10V, record the discharge time	≥60%

6. 机械性能 Mechanical Performance

名称 Item	测试条件 Condition	要求 Specification
挤压测试 Crush Test	将电池放在平板间进行挤压, 其压力通过一个直径位 32mm 的液压缸进行施压, 直到压力达到 17.2Mpa, 施加的压力为 13KN, 当达到压力后泄压 A battery is to be crushed between two flat surfaces. The force for the crushing is to be applied by a hydraulic ram with a 32mm diameter piston. The crushing is to be continued until a pressure reading of 17.2mmPa is reached on the hydraulic ram, applied force of 13kN. Once the maximum pressure has been obtained it is to be released.	不起火, 不爆炸 No fire, No explosion
跌落测试 Drop Test	将电池样品由高度 1m 的位置自由跌落到置于水泥地面上的钢板上, 并从圆柱电池的两个轴向正负方向(四个方向)每个方向自由跌落 1 次 The battery has only two axes of symmetry in which case only two directions shall be tested. The battery is to be dropped from a height of 1 meter twice onto concrete ground.	不爆炸, 不起火, 不冒烟 No explosion, No fire, No smoke
振动测试 Vibration	将充满电后的电池固定在振动台上, 沿 X,Y,Z 三个方向各振动 30 分钟, 振幅 1.6mm A full-charged battery is to be subjected to simple harmonic motion with an amplitude of 1.6mm total maximum excursion. The frequency is to be varied at the rate of 1 hertz per minute between 10 and 55 hertz. The cell shall be vibrated for 30 minutes per axis o XYZ axes.	不漏液, 不起火, 不爆炸 No leakage, No Fire, No explosion

7. 电芯安全性能 Cell Safety Performance

名称 Item	测试条件 Condition	要求 Specification
过充电测试 Over charge	在 20±5℃ 状态下, 电池用 1C 电流充电至 4V, 然后恒压 4V 让电流下降接近为 0A, 监视电池温度变化, 当电池温度下降一峰值低约 10℃ 时, 停止实验. At 20±5℃, charging battery with constant current 1C to voltage 4V, then with constant voltage 4V till current decline to 0.	不冒烟, 不起火 No explosion, No fire
过放电测试 Over discharge	.在 20±5℃ 状态下, 按标准放电的要求放电至终止电压后, 外接 30mΩ 负载放电 24 小时. At 20±5℃, according to the requirement of the standard of discharge after discharge to termination voltage, 30 m Ω external load discharge within 24 hours.	不起火, 不冒烟, 不漏液 No explosion, No fire
短路测试 Short-circuit	在 20±5℃ 状态下, 标准充电后, 将电池的正负极用一根小于 50mΩ 的导线连接, 放置 6 小时. At 20±5℃, Standard charge, across the electrodes of the battery with a less than 50 m Ω wire connection, 6 hours	不爆炸的, 不起火 表面的温度低于 150℃ No explosion, No fire The temperature of the surface of the cell are lower than 150℃
加热测试 Heating	将电池放置在真空箱中, 以每分钟 5±2℃ 频率加热, 一直到 130℃, 放置 30 分钟 Battery is heated in a circulating air oven at a rate of 5±2℃ per mins to 130℃, an then placed 30 mins at 130℃	不起火, 不冒烟 No explosion, no fire

8. 出货带电量 Delivery Conditon

正常情况下, 电池出厂前带电量 50-70%, 如有特殊要求, 需提出后确认, 出货电压: 12.4-13.6V
Approx. 50-70% charged
Shipment voltage: 12.4-13.6V

9. 产品外观尺寸 Appearance& Dimension:

外观尺寸 Dimension: 331*171*220 mm





Warning!

Before the battery needs to be connected in series or in parallel, please confirm details with us.

在电池需要串联或并联连接使用之前，请先与我们确认详细信息。

10. 警告 Warnings

为防止电池可能发生的泄漏,发热,起火,请注意以下预防措施:

To prevent the possibility of the battery from leaking, heating, fire, Please READ this specification carefully before usage and observe the following precautions:

◎充电时请选用磷酸铁锂电池专用充电器.

◎电池外包装膜易被镍片,尖针等尖锐部件损伤,禁止用尖锐部件碰伤电池

◎严禁将电池浸入海水或水中.

◎禁止将电池在热高温源旁,如火,加热器等使用设备.

◎禁止颠倒正负极使用电池

◎禁止将电池直接接入电源插座

◎禁止将电池丢入火或加热器中

◎电池极耳的机械强度不坚固,特别是铝极耳,禁止弯折.

◎禁止用金属直接将电池的正负极进行短路连接

◎禁止将电池与金属,如发夹,项链等一起运输或贮存

◎禁止敲击或抛掷,踩踏电池等.

◎禁止直接焊接电池和用钉子或其它利器刺穿电池.

◎When recharging, use the LiFePO4 battery charger specifically for that purpose

◎Do not strike battery with any sharp edge parts, such as Ni-tabs, pins and needles

◎Do not immerse the battery in water and seawater

◎Do not use and leave the battery near a heat source as fire or heater

◎Do not reverse the position and negative terminals

◎Do not connect the battery to an electrical outlet

◎Do not discard the battery in fire or heat it

◎The battery tabs are not so stubborn especially for aluminum tab. Do not bend tab.

◎Do not short-circuit the battery by directly connecting the positive and negative terminal with metal object.

◎Do not transport and store the battery together with metal objects such as necklaces, hairpins etc.

◎Do not directly solder the battery and pierce the battery with a nail or other sharp object.

11. 电池操作说明 Battery operation instruction

11.1 充电

Charging 充电电流: 不能超过规格书规定的最大的充电电流

充电电压: 不能超过规格书规定的最高的限制电压

充电温度: 电池充电温度必须按照规格书的温度范围执行

先恒流后恒压方式充电，禁止颠倒的方式充电。如果电池正负极颠倒充电会带来危险。

Charging current: Do not surpass the biggest charging current which in this specification.

Charging voltage: Do not surpass the highest voltage which in this specification.

Charge temperature: The charge temperature is in according to this specification.

11.2 放电电流 Discharging

电池放电电流不能超过规格书规定的最大放电电流，

过大的电流放电会造成电池发热和容量衰减。

电池放电温度必须按照规格书的温度范围执行

Discharge current: Do not surpass the biggest discharge current which in this specification.

Discharge voltage: Do not be less than the lowest voltage which is in this specification.

Discharge temperature: The discharge temperature is in according to this specification,

11.3 过放电 Over-discharges

短时间的过充过放不影响电池的使用，但是长时间的过放电会影响到电池的功能失效，电池永久性不能适用，可能电池过放还有一个原因是自动能量的消失。预防电池过放的出现方法电池应保持一定的电量。After the short time excessively discharges charges immediately cannot affect the use, but the long time excessively discharges can cause the battery the performance, battery function losing. The battery long-term has not used, has the possibility to be able to be at because of its automatic flashover characteristic certain excessively discharges the condition, for prevented excessively discharges the occurrence, the battery should maintain the certain electric quantity.

11.4 贮存电池 Storing the Batteries

电池贮存在规格书规定的温度范围内，如果电池贮存超过三个月，建议你开始给电池充电。

The battery should store in the product specification book stipulation temperature range. If has surpasses above for 3 months the long time storage, suggested you should carry on additional charge to the battery.

11.5 Please do not continuously charge the battery over 8hours.

请不要连续充电电池超过 8 小时。

12. 其他事项 Others

©客户若需要将电池用于超出文件规定以外的设备，或在文件规定以外的使用条件下使用电池，应事先联系广州美力特动力科技有限公司，因为需要进行特定的实验测试以核实电池在该使用条件下的性能及安全性。

©对于在超出文件规定以外的条件下使用电池而造成的任何意外事故，广州美力特动力科技有限公司概不负责。

©如有必要，广州美力特动力科技有限公司会以书面形式告之客户有关正确操作使用电池的改进措施。

©任何本说明书中未提及的事项，须经双方协商确定

©The customer is requested to contact MERITSUN in advance, if and when the customer needs other applications or operating conditions than those described in this document. Additional experimentation may be required to verify performance and safety under such conditions.

©MERITSUN will take no responsibility for any accident when the battery is used under other conditions than those described in this Document.

©MERITSUN will inform, in a written form, the customer of improvement(s) regarding proper use and handing of the battery, if it is deemed necessary.