

# EcoFlow 220W Lightweight Portable Solar Panel

Thank you for choosing our product.



## Contents

About This Manual

Overview

Get Started

Power Your Devices

Prerequisites

How to Connect

Maximize Power Output

Find an Ideal Environment

Wire Your Panels

Storage and Maintenance

Storage

Cleaning

FAQ

What's in the Box

Specifications

Safety Instructions

Disclaimer



FAQs



EcoFlow App



After-sales  
Policy

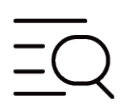

Downloads

## About This Manual

- This manual contains an introduction to this solar panel, and details on its operation, management, and maintenance. Please note that this manual may be updated without prior notice.
- All images displayed in this manual are for demonstrative purposes only. Please refer to the actual product received.
- If you are reading this manual in PDF format, please note that you can access it online at [EcoFlow Support](#) for a better experience and the latest updates.

## Overview

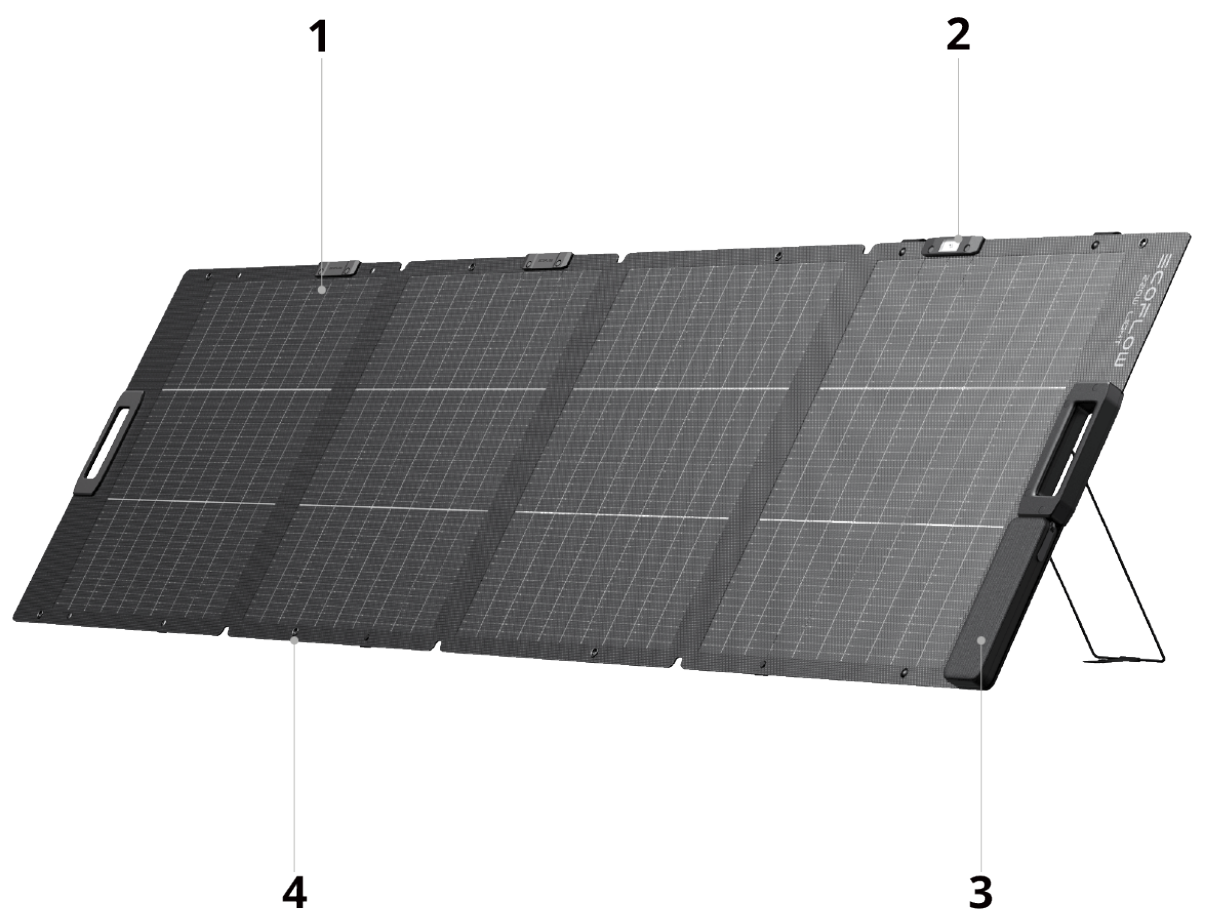

- 1 Photovoltaic module (Front)** Contains a solar angle guide and a junction box. Face this side to the sun during use. It's recommended to use the panel on sunny days with ample sunlight.
- 2 Solar angle guide** Indicates the angle between the sunlight and the panel. If the shadow of the black dot hits the center of the plate, you get a 90° angle.
- 3 Cable pouch** Includes an XT60i solar output cable (2.5 m).
- 4 Eyelet hole** The panel is designed with 8 preset mounting holes (inner diameter: 8 mm), which can be used with ropes, hooks, or other fixtures to securely hang or install the panel.

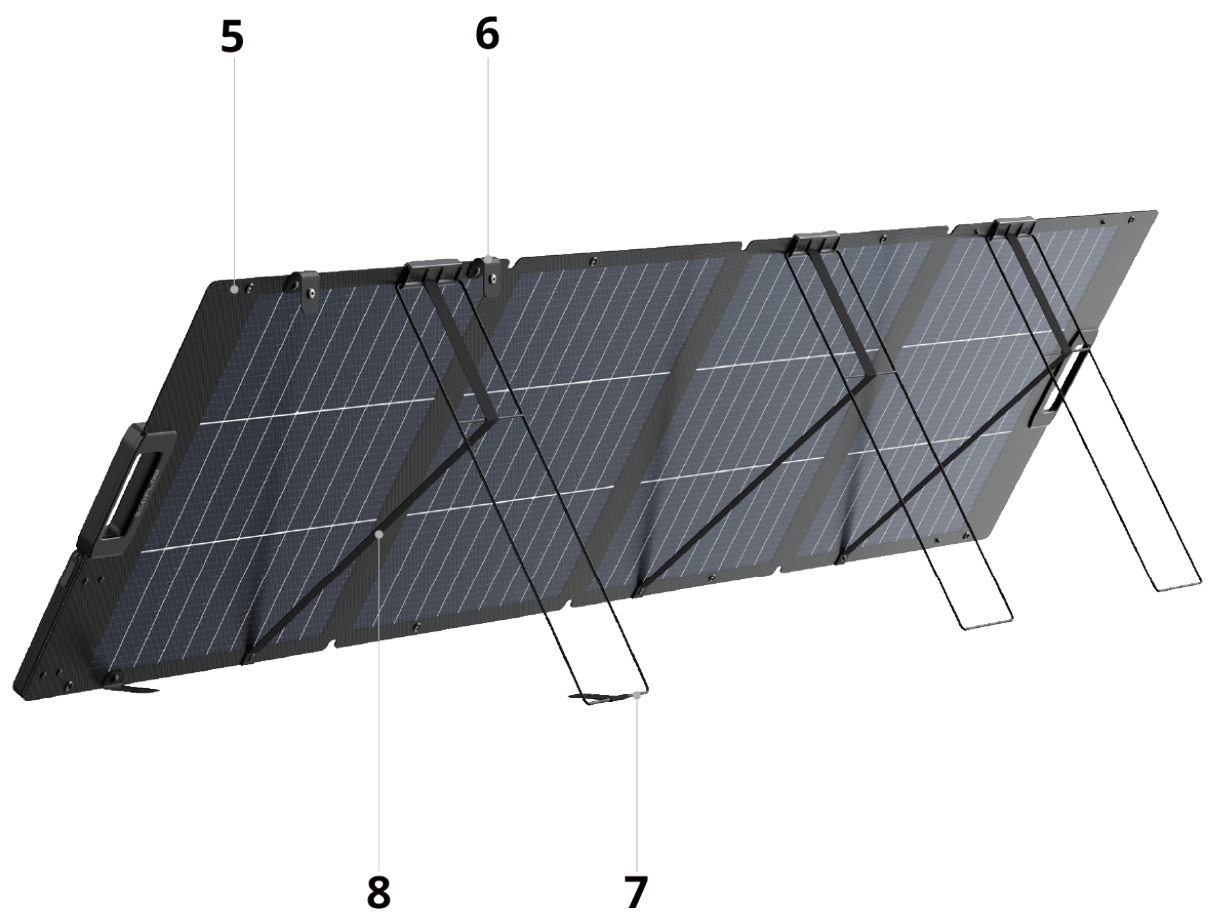

- 5 Solar Panel – Back Side** Equipped with 3 kickstands. This side should face away from the sun during use.

<b>6 Buckle</b>	Comes with 4 pieces, used to fasten and secure the solar panel for storage.
<b>7 Kickstand</b>	Contains elastic straps, making it easy to adjust the panel's angle.
<b>8 Elastic Strap</b>	Used to adjust the angle, allowing the solar panel to be positioned between 30° and 60°.

## Get Started

- 1** Unfasten the 4 buckles. Face the junction box toward the sun, and unfold one rear kickstand to support the panel.

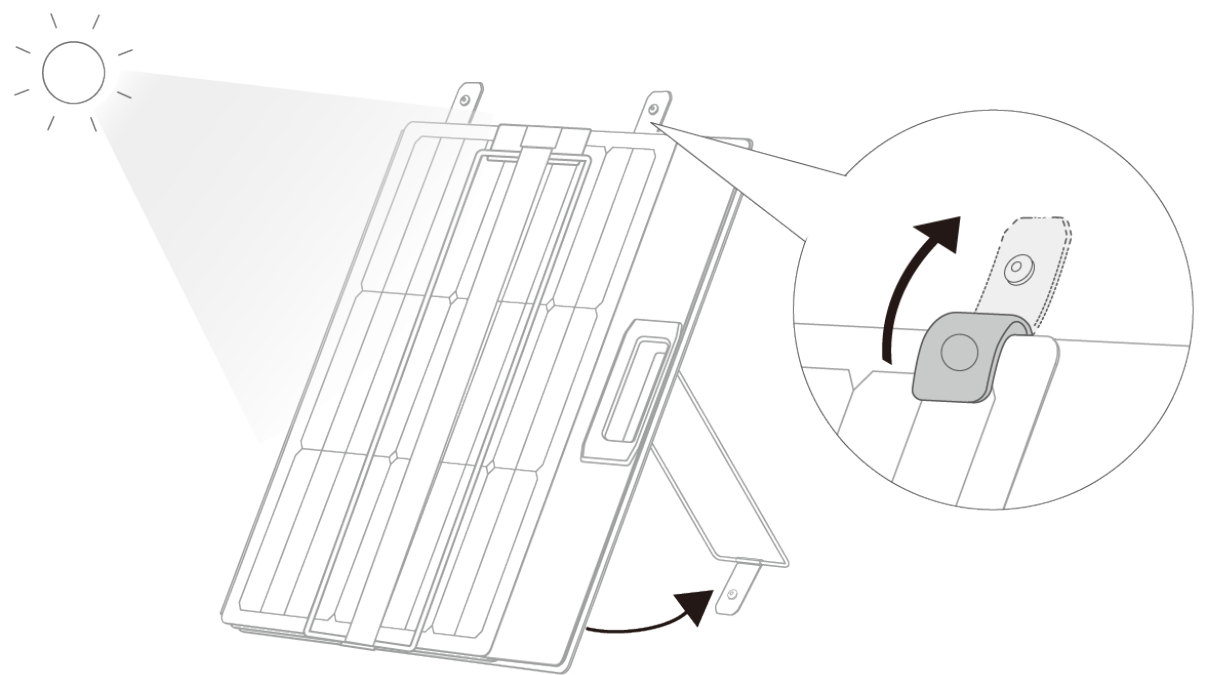

- 2** As shown in the picture, it's recommended to unfold the kickstand first before unfolding the panel.

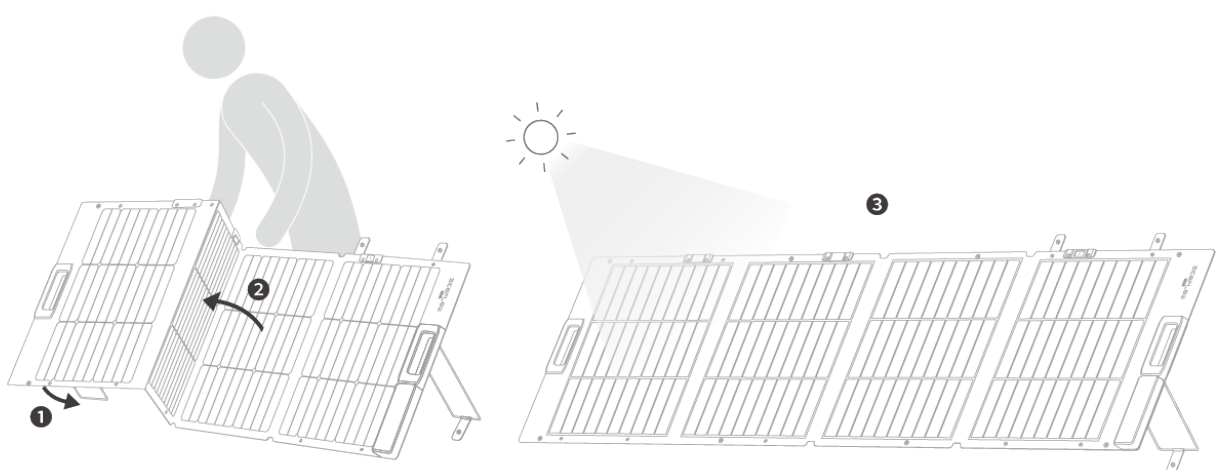

**i** It's recommended to stand behind the panel when unfolding it to save effort.

- 3** Check the dot shadow on the solar angle guide to adjust the kickstands, and let the shadow hit as close to the center as possible.

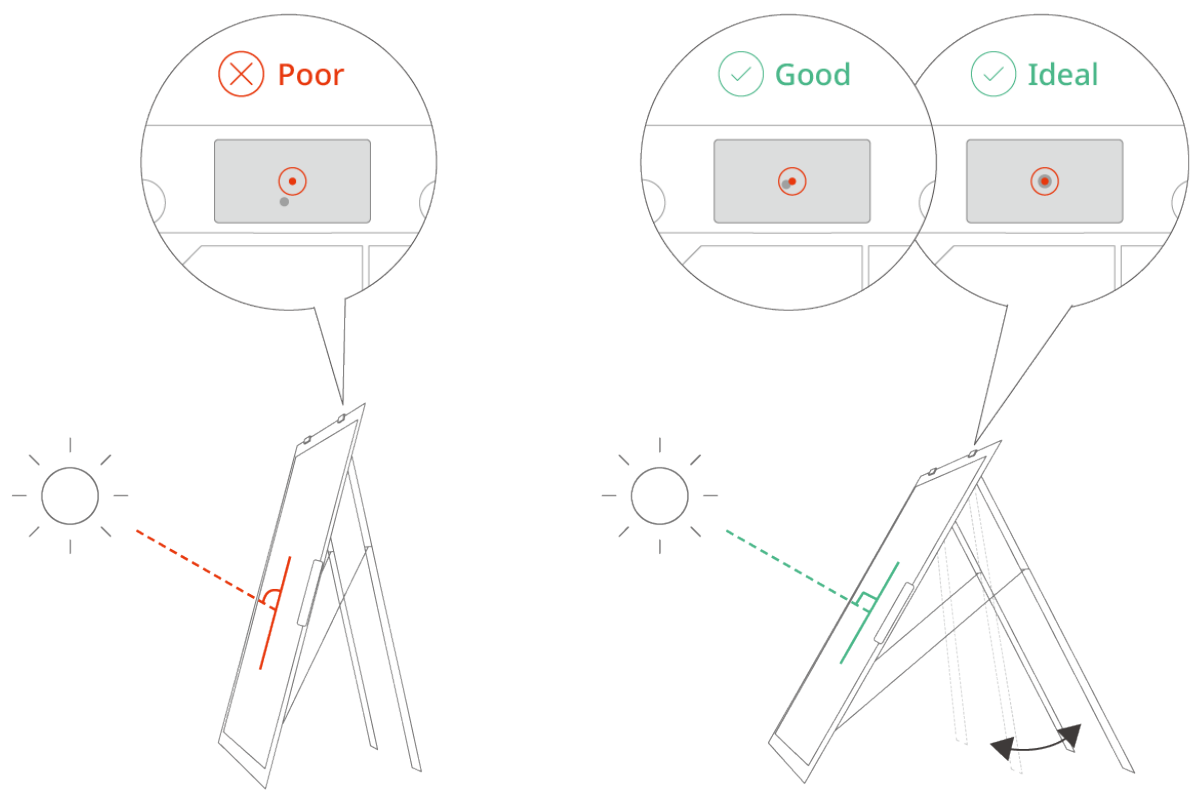

#### Tips

- Do not let the shadow leave the red circle on the angle guide. Otherwise, the power output will decrease.
- When the dot shadow hits the center, you get a 90° angle and the highest power output.

## Power Your Devices

### Prerequisites

You can connect the solar panel directly to the EcoFlow portable power station to store energy. Alternatively, you can connect the EcoFlow portable power station to EcoFlow smart devices to supply power directly.

When using the panel with your devices, please make sure the **maximum output parameters**<sup>1</sup> of the panel are within the input range of the devices. Otherwise, your devices may be damaged. To connect the panel with a third-party device, please make sure that the device allows solar input, and that its output ports and electrical parameters meet the panel's requirements.



#### Maximum output parameters<sup>1</sup>

For this product, the open-circuit voltage of a single **220W** solar panel is **21.4V**, and the short-circuit current is **12.2A**.

### How to Connect

**1**

When the panel is in place, connect the solar panel's XT60i output cable to the EcoFlow portable power station's **solar input port (XT60)**<sup>1</sup> to complete the electrical connection.

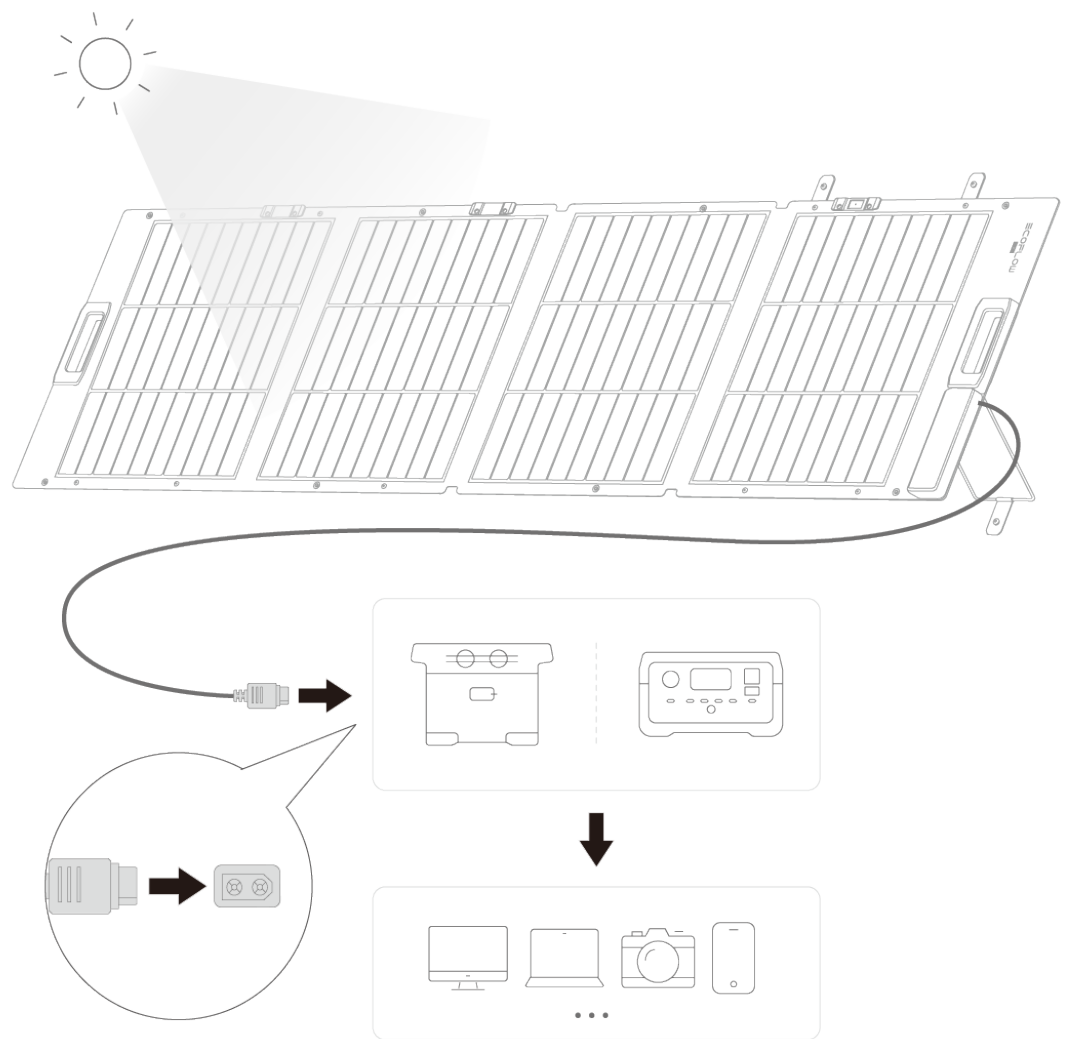

#### **Solar input port (XT60)<sup>1</sup>**

Make sure the cables were connected firmly before use to avoid port melting caused by bad connection.

**2**

If the panel is connected to an EcoFlow device, you can check real-time output data on the screen of the device or on the device's homepage of EcoFlow app.

## **Maximize Power Output**

### **Find an Ideal Environment**

- **Use the panel on sunny or mostly sunny days**

On a sunny noon, sunlight is strong and the panel yields more power. On cloudy or rainy days, sunlight is weak and the panel's output decreases as a result.

- **Minimize shading**

Keep the panel free from shading, dust, leaves, droppings, or other debris. Otherwise, the panel's power output will decrease dramatically.

- **Ensure a 90° tilt angle**

The direction of sun rays changes throughout the day. It's recommended to check the dot shadow on the solar angle guide from time to time and make sure it remains in the middle.

## Wire Your Panels

You can wire panels in series or in parallel to get higher output. When wiring, pay attention to the electrical parameters of your solar array and make sure that the parameters meet the requirements of the device that the panels will be connected to. **Generally speaking, it's recommended to wire solar panels in series for connecting with a EcoFlow portable power station.**

### How to Connect

- To wire **in series**, plug the two panel output leads into the two input sockets of the **EcoFlow XT60i In-Series adapter (marked "In-Series")**. Then connect the adapter's single XT60i plug to the portable power station's solar input (XT60/XT60i). The adapter internally puts the two panels in series.

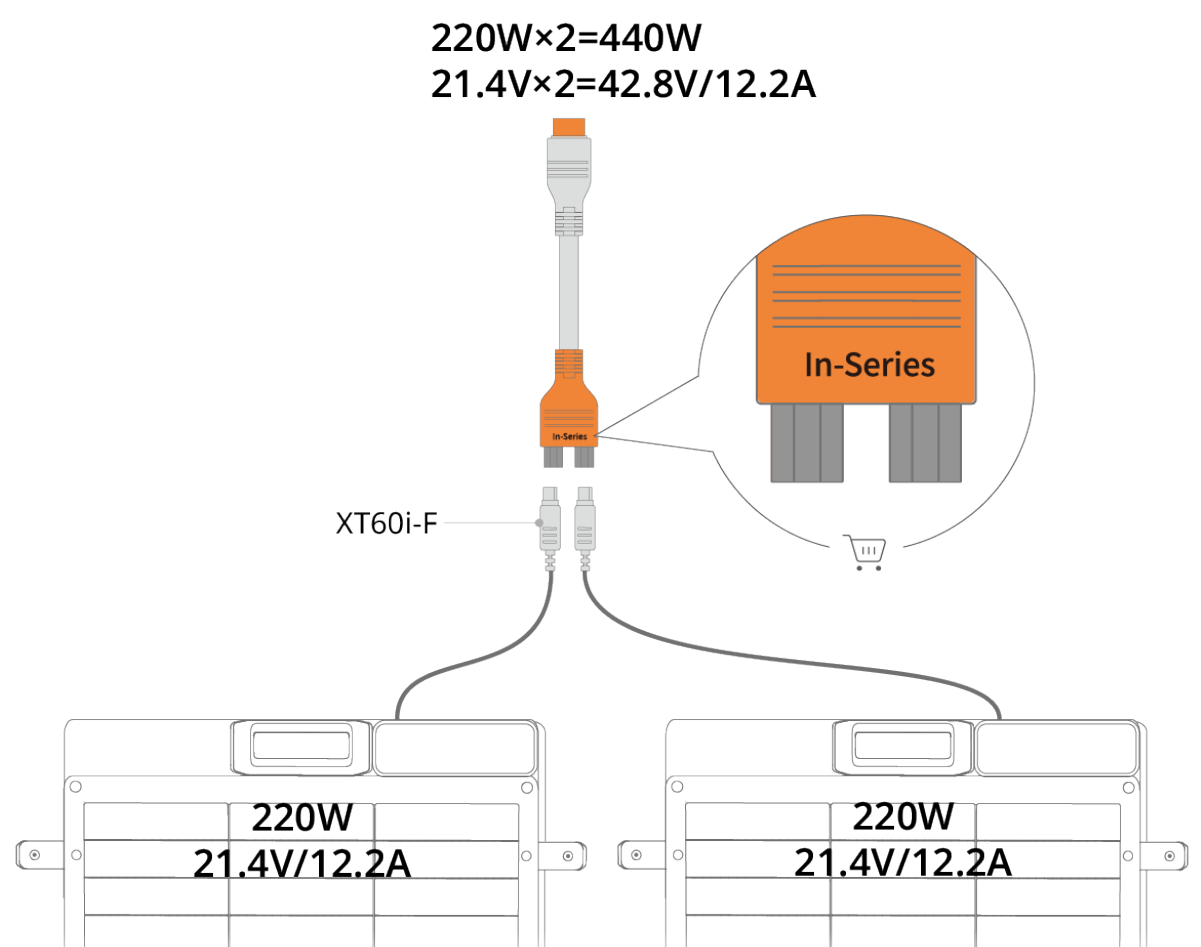

**i** The **EcoFlow XT60i In-Series Adapter (marked "In-Series")** is not part of the box contents. Please purchase it separately from the EcoFlow online store.

- To wire **in parallel**, plug the two panel output leads into the two input sockets of the **EcoFlow XT60i In-Parallel adapter (marked "In-Parallel")**. Then connect the adapter's single XT60i plug to the portable power station's solar input (XT60/XT60i). The adapter internally puts the two panels in parallel.

$$220W \times 2 = 440W$$

$$21.4V / 12.2A \times 2 = 24.4A$$

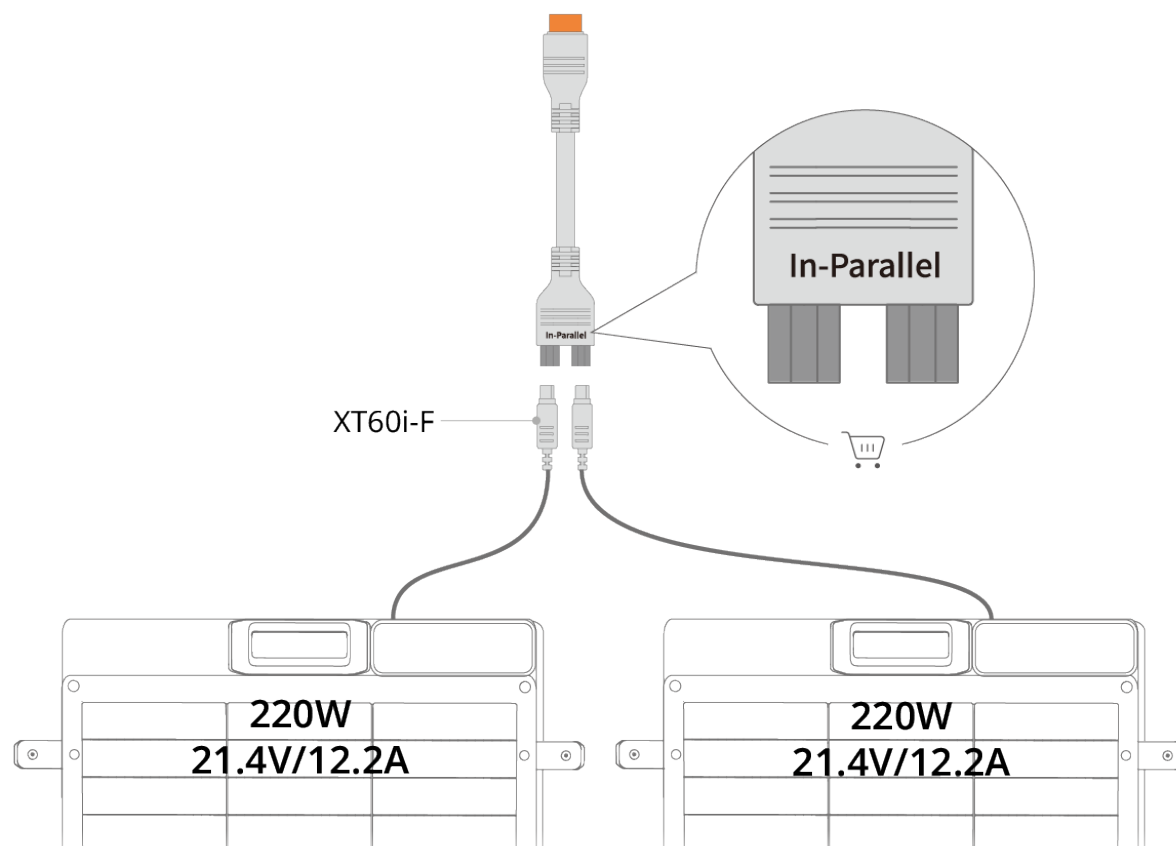

**i** The EcoFlow XT60i In-Parallel Adapter (marked "In-Parallel") is not part of the box contents. Please purchase it separately from the EcoFlow online store.

### Select Your EcoFlow Portable Power Station

- A single 220W lightweight solar panel can be used independently to meet basic daily charging needs.
- For better performance in low-light conditions, it is recommended to connect two 220W portable solar panels in series, which allows for more efficient charging of EcoFlow portable power stations. Connecting the panels in parallel may result in an overall current that exceeds the supported input limits of EcoFlow portable power stations; therefore, parallel connection is not recommended.

Recommended configurations by model are shown below.

No.	Power Station Model	Battery Capacity	Max. PV Input Power	Recommended 220W Solar Panel Quantity
1	DELTA 2	1024Wh	500W / 60V	2 panels (series)
2	DELTA 3	1024Wh	500W / 60V	2 panels (series)
3	WAVE 3 Battery	1024Wh	400W / 60V	2 panels (series)
4	DELTA 3 1500	1536Wh	500W / 60V	2 panels (series)
5	RIVER	288Wh	200W / 25V	1 panel
6	RIVER 3 Plus	286Wh	220W / 55V	1 panel
7	RIVER 2 Max	512Wh	220W / 50V	1 panel
8	RIVER 3 Max	576Wh	220W / 55V	1 panel

9	RIVER Max	576Wh	200W / 25V	1 panel
---	-----------	-------	------------	---------

10	RIVER 2 Pro	768Wh	220W / 50V	1 panel
----	-------------	-------	------------	---------

## Storage and Maintenance

### Storage

- When the solar panel is not in use, disconnect it from all devices, fold it properly, and store it in an upright position. Avoid placing heavy objects on top of the panel.
- For long-term storage, neatly bundle the output cables and secure them inside the cable pouch to prevent contact or pressure against the solar cells. Then fold the solar panel and place it back into the carrying case. Store the panel in a cool, dry location, away from direct sunlight, high temperatures, or humid environments.

### Cleaning

- Make sure the panel is not connected to portable power stations or other loads, and that the panel's surfaces have cooled to room temperature. Then, wet a soft rag with clean water, twist dry the rag, and clean the panel's surfaces with it. Avoid wiping or washing the photovoltaic connectors when cleaning.

## FAQ

### 1. Is the panel waterproof?

The panel has an IP68 rating. If the panel gets wet in the rain or falls into water by accident, check if water has got into the connectors immediately. If yes, dry the connectors with rags and the panel will function properly. However, pay attention not to soak the panel in water.

### 2. Why isn't my panel generating power?

Make sure the connection is correct, the terminals are tight, and the environmental conditions, including sunlight, are ideal for solar power generation. If the panel still generates no power after you exclude the factors above, contact EcoFlow's official customer service for help.

### 3. Can portable solar panels generate power with weak light, like on rainy days or under indoor lighting?

Portable solar panels barely generate power under such circumstances as they are made of monocrystalline cells, whose performance is restricted by weak

light.

#### 4. Is the panel compatible with all EcoFlow portable power stations?

Not necessarily. It depends on whether the panel's electrical parameters match the solar input specifications of the power station.

The 220W lightweight panel has an open-circuit voltage of 21.4V and a short-circuit current of 12.2A. Please check that these values are within the supported range of your EcoFlow portable power station (e.g., maximum power point voltage/current).

#### 5. How can the 220W lightweight solar panel be connected in series or parallel? Where can I obtain the required accessories?

This product is recommended to be connected in series with the same model 220W solar panel for use with EcoFlow portable power stations. Parallel connection is not recommended, as the resulting current may exceed the input limits of the portable power station.

For series connection, please purchase the appropriate series adapter cable according to your specific usage needs.

## What's in the Box

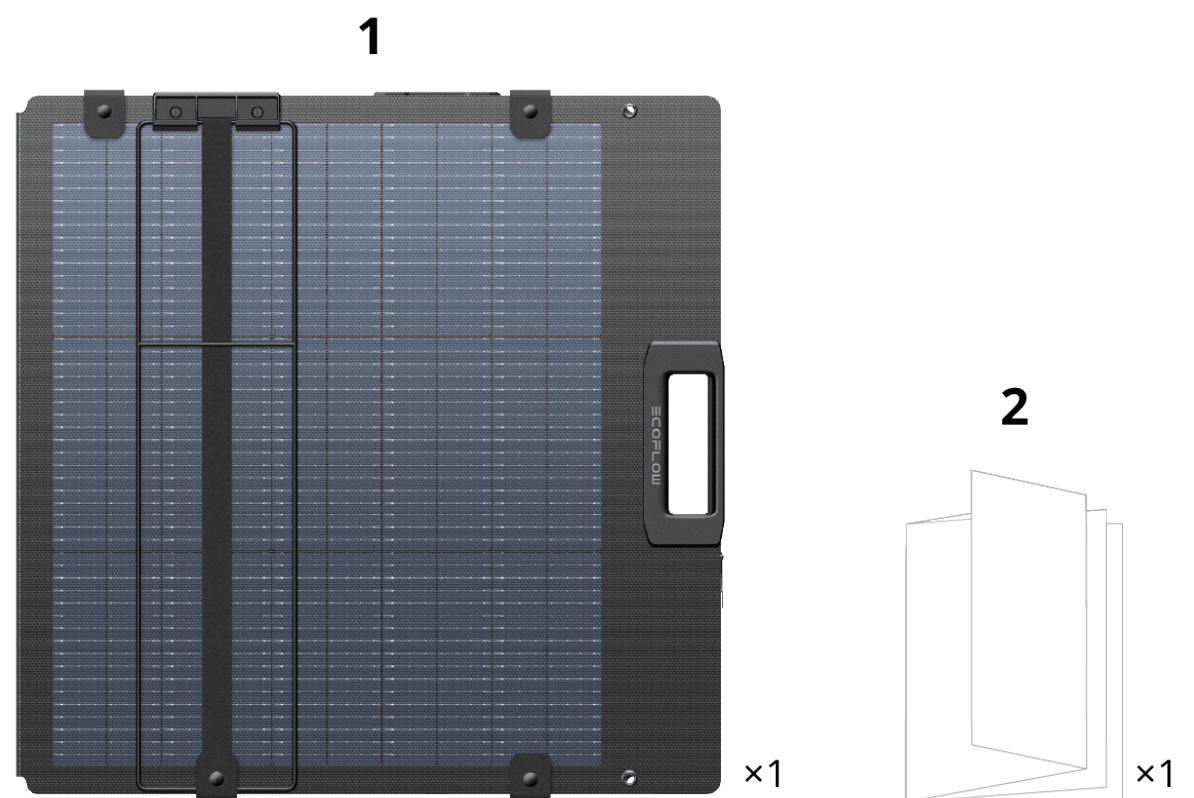

- 
1. EcoFlow 220W Lightweight Solar Panel
  2. Quick Start Guide, Safety Instructions, Warranty Card
- 

## Specifications

Parameters	
Model	EF-FOLD-220-LW
	220W±5W (STC)

Rated Power	243W±5W (BNPI)
Open Circuit Voltage	21.4V
Short Circuit Current	12.2A (STC) 13.5A (BNPI)
Optimal Operating Voltage	18.8V
Optimal Operating Current	11.7A (STC) 12.9A (BNPI)
Recommended Ambient Temperature	-40°C to 85°C (-40°F to 185°F)
Temperature Coefficient of Rated Power	-0.30%/°C
Temperature Coefficient of Open Circuit Voltage	-0.25%/°C
Temperature Coefficient of Short Circuit Current	+0.045%/°C
Bifaciality	80% ±5%
IP Rating	IP68

#### Dimensions

Weight	Approx. 5.1 kg (11.24 lbs)
Unfolded Dimensions	2270 × 598 × 26 mm (89.37 × 23.54 × 1.02 in)
Folded Dimensions	603 × 598 × 36 mm (23.74 × 23.54 × 1.42 in)

#### Battery Specifications

Cell Type	TOPCon monocrystalline silicon
Solar Cell Efficiency	≥25%
Connector Type	XT60

- Standard Test Conditions: 1000W/m<sup>2</sup> (92.9W/ft<sup>2</sup>), AM1.5, 25°C (77°F)
- Bifacial Standard Test Conditions (BSTC/BNPI): Front side 1000W/m<sup>2</sup> (92.9W/ft<sup>2</sup>), rear side 135W/m<sup>2</sup> (12.5W/ft<sup>2</sup>), AM1.5, 25°C (77°F).
- When the temperature is too high or too low, the panel's open circuit voltage and short circuit current will vary.

The parameters and specifications of this product are measured under **Standard Test Conditions (STC)** or **Bifacial Standard Test Conditions (BSTC/BNPI)**.



The actual power generation may vary due to factors such as geographical location, solar irradiance intensity and duration, climate conditions, temperature, shading, installation angle, system configuration (e.g., cable loss), and natural degradation over time. As a result, the actual output may differ from the rated values.

# Safety Instructions

## Disclaimer

Please read the product document and ensure that you understand it fully before using the product. After reading this document, keep it for future reference. Improper use of this product may cause serious injury to yourself or others, or cause product damage and property loss. Once you use this product, it is deemed that you understand, approve and accept all the terms and content in this document.

**EcoFlow is not liable for any loss caused by the user's failure to use the product in compliance with the product document.**

1. Do not wet the product, or leave it in a humid environment for an extended period of time. Do not allow the junction box or wire connectors to come into contact with liquids.
2. Any loss or damage caused by the user's intentional violation of the following safety requirements shall not be considered a product quality issue. The EcoFlow shall not be held liable in such cases. For example:
  1. Exposing any component of the product to highly corrosive materials such as corrosive organic solvents.
  2. Applying chemicals (such as paint or adhesives) to the sun-facing side of the solar panel.
  3. Using this product near open flames or flammable or explosive materials.
  4. Poking, puncturing, or scratching the solar panel with sharp or pointed tools, or wiping its surface with abrasive materials such as sandpaper.
  5. Knocking, squeezing, or bending the solar panel. It is recommended to place the product upright during transportation or storage.
  6. Placing heavy objects on the solar panel, which may cause damage during use.
  7. Using devices such as magnifying glasses to concentrate sunlight on the solar panel.
  8. Allowing children or pets to handle or play with this product.
3. Any loss or damage caused by external factors shall not be considered a product quality issue and is not covered under the EcoFlow's free warranty. Such external factors include but are not limited to bird droppings causing corrosion, animal bites, electrical surges, and extreme weather conditions (such as hail, heavy rain, strong winds, or lightning).
4. This product is designed for portable use, and the load-bearing capacity of the eyelet holes is limited. Under resistance testing at 60°C–70°C, the minimum breaking force of a single eyelet is greater than 120N. Users must secure the product properly during use and store it promptly in strong wind conditions. Do not hang the product for extended periods in high wind or high-temperature environments. Any damage to the eyelets, product failure, or injury/property loss to third parties caused by improper fixation or wind impact shall not be considered a product quality issue, and the manufacturer shall not be held liable.
5. Do not disassemble any component of the product by yourself, as this will

void the warranty.

6. When using this product to charge an energy storage power source, please make sure it complies with the requirements for parameters and specifications. If you connect multiple solar panels in series or parallel, please verify the maximum number of solar panels that can be connected to the power source in advance.
7. When connecting this product in series or parallel, it is recommended that you purchase connecting wires through EcoFlow's official sales channels. If you are using a third-party solar panel cable, make sure that the connector and the voltage and current of the cable are compatible.
8. Do not connect or disconnect any cables while the solar panel is operating, as this may cause electric arcs, short circuits, melting, or electric shock hazards. If it is necessary to connect or disconnect cables, please follow the steps below strictly:
  1. Move the solar panel out of direct sunlight, or completely cover the surface with an opaque cloth/shade board to ensure it is no longer generating electricity.
  2. Turn off all electrical equipment connected to the solar panel (such as inverters, power stations, or controllers).
  3. If the system is equipped with circuit breakers or switches, please turn off both the DC and AC power supply first.
  4. Wear insulating gloves and use insulated tools to check that there is no voltage at the connectors before proceeding.
  5. When connecting or disconnecting, press the locking tab gently and pull or insert smoothly. Do not operate under load, with wet hands, or while wearing metal accessories.
  6. After reconnecting, ensure the connectors are dry, secure, and fully locked, then restore the power supply and check the system status.
9. Do not wear any metal accessories when plugging or unplugging the solar panel.
10. Do not dispose of waste solar panels at will, please follow local laws and regulations for their disposal.
11. Ensure that all connectors are firmly secured during use to prevent overheating, melting, or performance degradation caused by poor contact.
12. Keep the panel surface clean after use. Avoid dust, stains, or obstructions that may reduce power generation efficiency.
13. Over time, solar panels may experience natural power attenuation. In addition, performance degradation caused by frequent folding, transportation, or external environmental factors is not covered under warranty.
14. **Warning:** This product generates direct current (DC) electricity when exposed to sunlight. Do not touch exposed conductive terminals or attempt to disassemble the product, as this may cause electric shock or burns. Always follow the instructions for proper connection and use. For long-term fixed installations, ensure that the supporting structure is secure, weatherproof, and wind-resistant. The company is not responsible for damage resulting from improper installation or external forces.

**Special Disclaimer:**

EcoFlow shall not be liable for any direct or indirect losses, damages, malfunctions, accidents, or personal injuries arising from the user's failure to comply with any of the above terms during the use of this product.

In compliance with laws and regulations, EcoFlow reserves the right to the final interpretation of this document and all documents related to the product. This document is subject to changes (updates, revisions, or termination) without prior notice. Please visit EcoFlow's official website to obtain the latest product information: <https://www.ecoflow.com/>.